

Manual FlexShade System

by **DRAPER**

Please check all appropriate selections and attach room schedule with verified dimensions.

Select Fabric (see page 2)

Color name, no., openness

- SheerWeave® SW2000/2100 _____
- SheerWeave® SW2600/2900 _____
- SheerWeave® SW3000 _____
- SheerWeave® PW3500/4100/4400 _____
- SheerWeave® PW4800 _____
- "E" Screen _____
- "M" Screen _____
- "T" Screen _____
- XL by Hexcel _____
- XL2 by Hexcel _____
- Flocké _____
- Obion _____
- Nocturne II _____
- SunBloc SB9000 _____
- SunBloc SB9100 _____
- CL8000 _____

Select Operator

- Spring Roller
 - Bead Chain/Clutch
 - Stainless Steel Chain (standard)**
 - Polyester Chain
 - Ivory
 - Grey
 - Black
 - Crank. Specify handle length (6' max.) _____
- Or, list sill ht. or ht. of unit off floor for proper handle length _____
- Fixed Handle (one per unit)
 - Detachable Handle
- Specify # of handles per job _____

Select Operator Location (except spring roller)

Select right side or left side as seen from inside the room, facing the window. Also indicate selection on room schedule.

- Right Side Control (standard)**
- Left Side Control

Select Hardware

- Brackets
- Headbox
- Pocket Box
- Inside/Outside
- Ceiling/Wall (Surface)
- Type D
- Ceiling
- Pocket Style
- Fascia

Select Hardware Finish

- Clear Anodized
- Black Enamel
- Ivory Enamel
- White Enamel
- Charcoal Bronze Enamel

Select Fabric Orientation

- Regular Roll (standard – from back of roller)**
- Reverse Roll (from front of roller) [Not available with fascia.]

Select Installation Option

- Inside (head/sill, jamb/jamb)
- Outside (overlap opening)
- Do any units abut at mullions? Which?
- Do any units install in pocket at ceiling? Which?

Dimensions—Clutch-Operated*

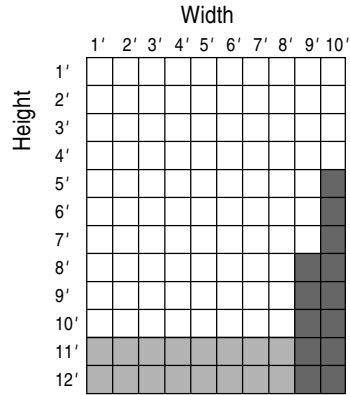

- Small endcaps/brackets are recommended.
- Large endcaps/brackets may be required.
- These sizes are not available.

Dimensions—Crank-Operated*

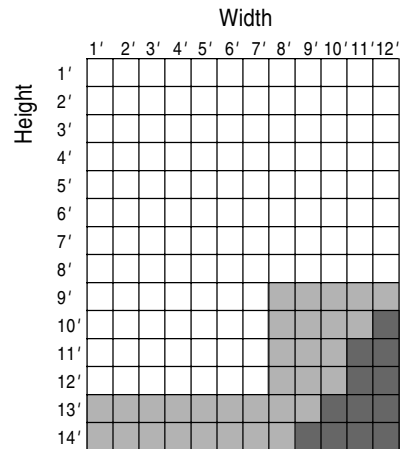

- Small endcaps/brackets are recommended.
- Large endcaps/brackets may be required.
- These sizes are not available.

* NOTE: Sizes requiring large endcaps/brackets will vary slightly according to fabric.

PROJECT: _____

ARCHITECT: _____

CONTRACTOR: _____

SUPPLIER: _____

DATE: _____ REVISED: _____

DRAPER

Specifications-Manual FlexShades

Equipment

Bead Chain Clutch Operator: High carbon steel and molded fiberglass-reinforced polyester. Bi-directional for mounting at either end of roller. Right hand standard. Control loop, of any length, is a plastic or nickel-plated brass bead chain. Metal standard. Plastic chain in ivory, grey, black. Never needs adjusting.

Crank Operator: Gear box, of die cast aluminum and steel, has ratio of 3.0 to 1. Bi-directional to mount at either end of roller. Right hand standard. Never needs lubrication or adjustment. Crank handle assembly, of anodized aluminum and chrome plated steel, up to 6' in length, detachable or permanently mounted (heavy duty crank optionally available in lengths to 10'). Crank roller insert, of injection molded nylon and steel, is installed in the roller and engages to gear box.

Spring Roller Operator: Institutional quality, all with heavy-duty springs. All shades are mounted on one piece electro-galvanized, or enamel, steel rollers.

Components

Rollers (except spring rollers): Sizes 1¹/₄" dia. x .030 wall, 1¹/₂" dia. with .065 wall, or 2" dia. with .080 wall, in steel or extruded aluminum. Roller assembly easily removable.

Mounting Brackets: 1018 plated steel stamping. Sizes 1⁵/₈" and 2¹/₄". Styles for mounting to face, ceiling, or jamb. Brackets do not require additional adapters.

Roller Idler Assembly: Type 6/6 injected molded nylon and a zinc-plated cold rolled steel pin. Sliding pin for easy installation and removal of the roller. Idler pin for 1¹/₄" dia. roller rotates in nylon bushing, which securely interlocks with mounting bracket.

Slat: Aluminum, min. 1/8" x 1", encased in heat seamed hem.

Endcaps: 1018 steel stamping. 2 sizes: 3¹/₄" x 3³/₄" and 4¹/₂" x 4¹/₂". Complete with adapter roller bracket. Installs to face, ceiling, or jamb. Accepts box covers and fabric guide. Clear anodized, black, white, ivory, or charcoal bronze baked enamel finish available.

Fascia: L-shaped cover of extruded aluminum, .060 wall. Snap-lock assembly to endcaps without exposed fasteners. Clear anodized finish or black, white, ivory, or charcoal bronze baked enamel finish.

Headbox: Standard consists of fascia, L-shaped back/top cover. Snap-lock assembly to endcaps. Optional, for pocket installation, includes a U-shaped back/top/front cover with removable bottom closure panel. Small size: 3¹/₂" x 4". Large size: 4³/₄" x 4³/₄". Some exposed fasteners required.

Carrier Bearing: 1018 steel stamping and type 6/6 injected molded nylon. Allows for multi-panel units utilizing one roller, up to a maximum of 16' in width. Mounts to mullion or ceiling.

Pocket Boxes: Shade pockets, Type (D/C) to be fabricated of 6063-T5 aluminum alloy for perimeter installation. Accepts FlexShades installed with ceiling brackets. Types D and C finished in white paint. Type D: 4⁵/₈" x 4¹/₂" x .125" with tile support lip and removable bottom closure. Type C: 3¹/₄" x 3¹/₄" x .060" with bottom closure.

Battens: In order to ensure proper flatness and tracking, Draper reserves the right to utilize metal battens, installed in pockets across entire width of shade.

Please note: Dimensions of rollers, operators and hardware at manufacturer's discretion.

Fabrics

Series SW2000/SW2100 SheerWeave®: 500 denier fiberglass, vinyl coated and woven into a 2 x 2 basketweave. 13.6 oz./sq. yd., .019" thick. Flame retardant rating: Meets NFPA 701 Small Scale and Large Scale. 96" max. roll width. SW2000 avg. 5% open; SW2100 avg. 10% open. Colors available: White, White/Bone, Bone, Bone/Platinum, White/Platinum, Platinum, Charcoal, Charcoal/Grey, Charcoal/Chestnut, and Bronze.

Series SW2900/2600 SheerWeave®: Fiberglass and PVC on fiberglass basketweave, .017" thick. Flame retardant. 96" max. roll width. **SW2900**—11.9 oz./sq. yd., 5% open. **SW2600**—10.5 oz./sq. yd., 10% open. Available colors: Pearl Grey, Beige, Oyster, Charcoal, Oyster/Pearl Grey, Oyster/Beige, Charcoal/Chestnut, Beige/Pearl Grey, Charcoal/Grey.

Series SW3000 SheerWeave®: Vinyl coated fiberglass and vinyl coated polyester woven into a 63 x 15 mesh. 14.8 oz./sq. yd., .027" thick. Flame retardant rating: Meets NFPA 701 Small Scale and Large Scale. 96" max. roll width. Avg. 14% open. Colors available: Mushroom Sand, Pearl White, Custard Cream, Mauve, Pale Grey,

Spanish Grey, Dusty Grey, Ninja Grey, Chocolate, Sand Dollar, Espresso, Honey Sage, Black Forest, Mossy Green, Harvest Wheat.

Series PW3500/PW4100/PW4400 SheerWeave®: Vinyl coated polyester yarn, thickness .030", woven into a basketweave. Flame retardant rating: Meets NFPA 701 Small Scale and Large Scale. 96" max. roll width. Colors available: Snowy White, Bone, Greystone, Soft Grey, Granite, Ash, Linen, Ebony, and Tobacco.

Series PW3500: avg. 5% open, 20 oz./sq. yd.

Series PW4100: avg. 10% open, 17 oz./sq. yd.

Series PW4400: avg. 3% open, 20.7 oz./sq. yd.

Series PW4800 SheerWeave®: Vinyl coated polyester, flame retardant, designed with privacy in mind and offers maximum UV blockage, with a 1% openness factor. Flame retardant rating: Meets NFPA 701 Small Scale. 18.5 oz./sq. yd., 96" roll width. Colors available: Alabaster, Peach, Teal, and Grey.

"E" Screen: PVC coated fiberglass yarn woven in a 2 x 2 basketweave. 11 oz./sq. yd., .016" thick. Flame retardant rating: Meets NFPA 701 Small Scale and Large Scale. 96" max. roll width. Colors available: White, White/Linen, Linen, White/Perlé, Perlé/Linen, Perlé, Charcoal/Grey, Charcoal, and Charcoal/Bronze.

ME Series: Avg. 6% open.

ME-10 Series: Avg. 10% open.

"M" Screen: PVC coated fiberglass in a 1 x 2 yarn weave. 12.7 oz./sq. yd., .022" thick. Flame retardant. 96" max. roll width. Colors available: White/Linen, White Pearl, Pearl Linen, Grey Lotus, Linen, Pearl, Charcoal Bronze, Charcoal, Grey Ultra, Grey Hunter Green, White, White Lotus, White Stone, Pearl Lotus, Linen Stone, Linen Ultra, Charcoal Grey, Charcoal Lotus, Charcoal Ultra, Charcoal Hunter Green. Avg. 3% and 5% open.

"T" Screen: PVC coated fiberglass, 12 oz./sq. yd., .026" thick. Flame retardant rating: Meets NFPA 701 Small Scale and Large Scale. 96" max. roll width. T Screen 5100 avg. 5% and T Screen 5110 avg. 10% open. Colors available: Blanc/Linen, Blanc/Linen-Perlé, Linen/Perlé-Gris, Charcoal/Linen-Perlé, Perlé/Bronze-Charcoal, Perlé/Blanc, Linen/Linen-Perlé, Linen/Gris-Bronze, Charcoal/Gris.

XL by Hexcel: PVC coated glass yarn, 11.5 oz. per sq. yd., .18" thick. Flame Retardant rating: Meets NFPA 701 Large Scale. 96" max. roll width. Approx. 5% open. Colors available: White, White/Linen, White/Pearl, Linen, Pearl/Linen, Pearl, Charcoal/Grey, Charcoal/Bronze, Charcoal.

XL2 by Hexcel: PVC coated glass yarn, Approx. 3%, 5%, & 10% open. Flame Retardant rating: meets NFPA 701 Large Scale. 96" max. roll width. 3% open .23" thick & 13.6 oz. per sq. yd.; 5% open .23" thick & 12.7 oz. per sq. yd.; 10% open .2" thick & 11.2 oz. per sq. yd. Colors available: White, White/Linen, White/Pearl, White/Grey, White/Bronze, White/Charcoal.

Flocké: Fiberglass textile with acrylic backing. 14.75 oz./sq. yd., .021" thick. Opaque. Flame retardant rating: Meets NFPA 701 Small Scale and Large Scale. Anti-static treated. 78" roll width. Colors available: Blanc, Mississippi, Beige, Soleil, Pastache, Mangue, Cuivre, Chêne, Seychelles, Petrole, Encre, Chartreux, Loutre, Noir, and Sahel.

Obion: Room darkening fiberglass textile with acrylic flocked backing. 10.03 oz./sq. yd., .0018" thick. Flame retardant rating: Meets NFPA 701 Small Scale and Large Scale. 78" roll width. Colors available: Blanc, Sahel, Mississippi, Chartreux.

Nocturne II: Coated Polyester, 5 oz./sq. yd., .019" thick. Flame retardant rating: Meets NFPA 701 Small Scale and Large Scale. 71" roll width. Opaque. Colors available: White, Buff, Creme, Grey, Beige, Green, Bottle Green, Red, Burgundy, Blue, Indigo, Yellow.

Series SB9000/9100 SunBloc: Close woven fiberglass base textile with sun-resistant vinyl film securely bonded to each side. Opaque, fire retardant, washable and stain resistant. Min. acceptable tensile strength: 190 lbs. warp x 180 lbs. fill. Wt. 12 oz./sq. yd. 72" roll width. Colors available: White, Ivory, Tan, Grey, Black, Champagne, Grey/White, Chocolate/White, Wheat/White, Rust/White, Putty/White, Forest/White, and Black/White.

Series SB9000 has same color both sides;

Series SB9100 has white exterior in all colors.

CL8000 (Colony): Close woven fiberglass base textile with sun-resistant vinyl film securely bonded to each side. Suitable for room darkening, fire retardant, washable and stain resistant. 90% opaque. All slat hems must be of same color as rest of shade, both inside and out. 72" roll width (Cobalt 54" roll width). Fabric White on outside.

Hardware Selections

Note: Brackets and endcaps have the only attachment points for mounting a manual FlexShade. The optional fascia and headbox have a thickness of 1/16".

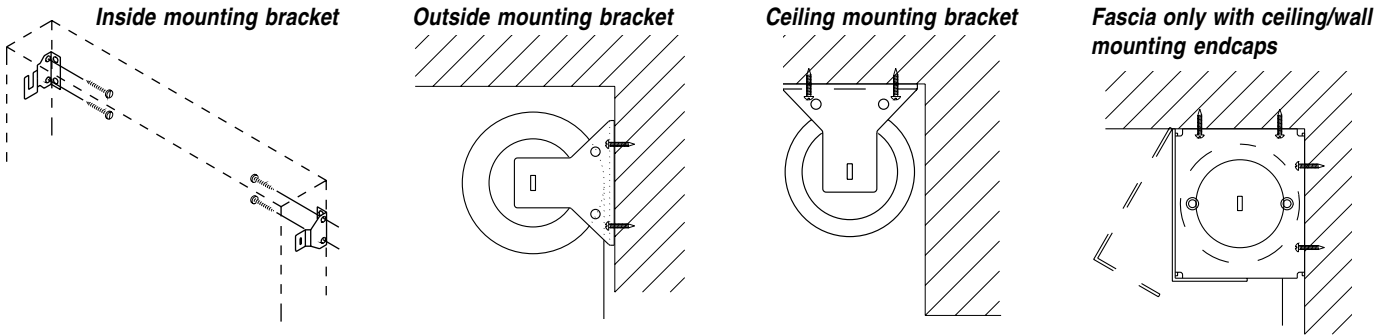

Headbox installation Options

Standard Headbox consists of fascia, back/top cover and ceiling/wall mounting endcaps

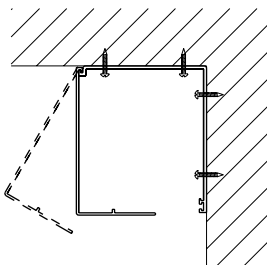

Optional Headbox consists of Draper's extruded pocket with bottom closure panel and ceiling/wall mounting endcaps

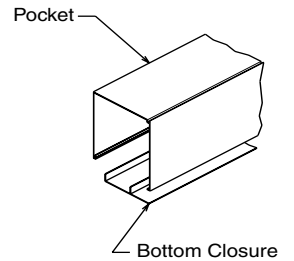
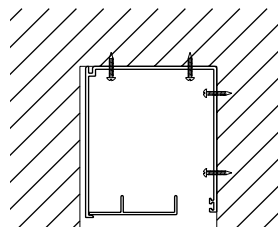

Pocket Box Options

Type D pocket, standard white in color, features a 4 1/2" x 4 5/8" cross-section. A lip along lower edge supports lay-in ceiling. Suitable for use with clutch operated FlexShades. Pre-welded corners and pocket ends are available. Ends come with or without tile support lip (shown).

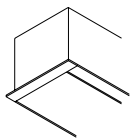

Typical pocket end (not to scale)

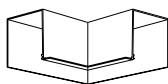

Typical pre-welded corner section (not to scale)

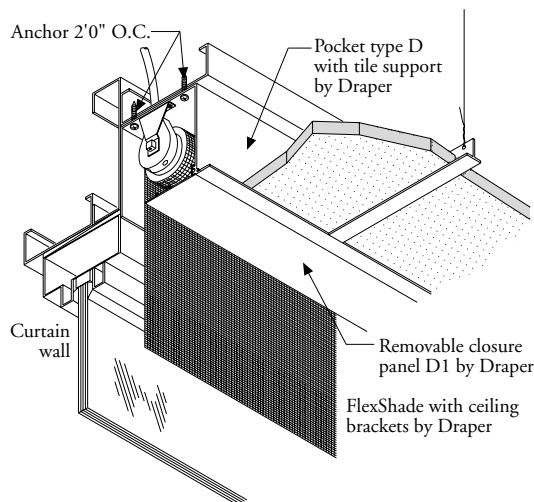

Cross Section of Type D Pocket

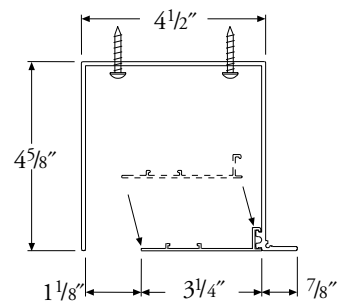

Clutch-operated FlexShade

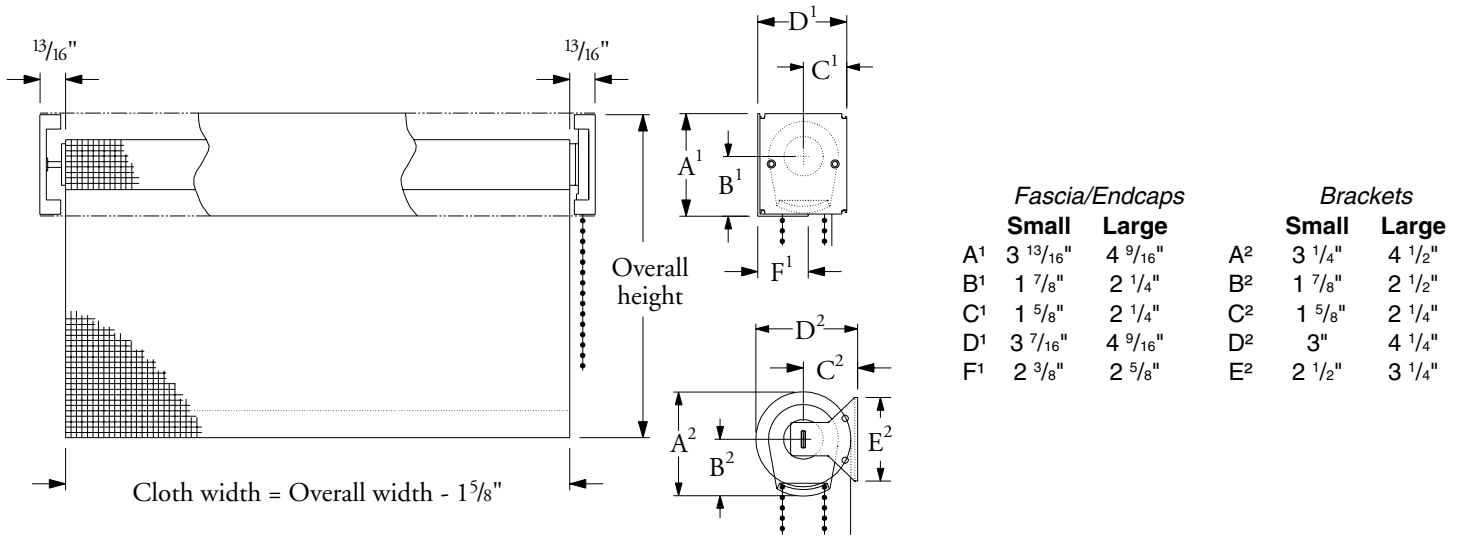

Crank Details

Crank-operated FlexShade, with standard endcaps and optional fascia

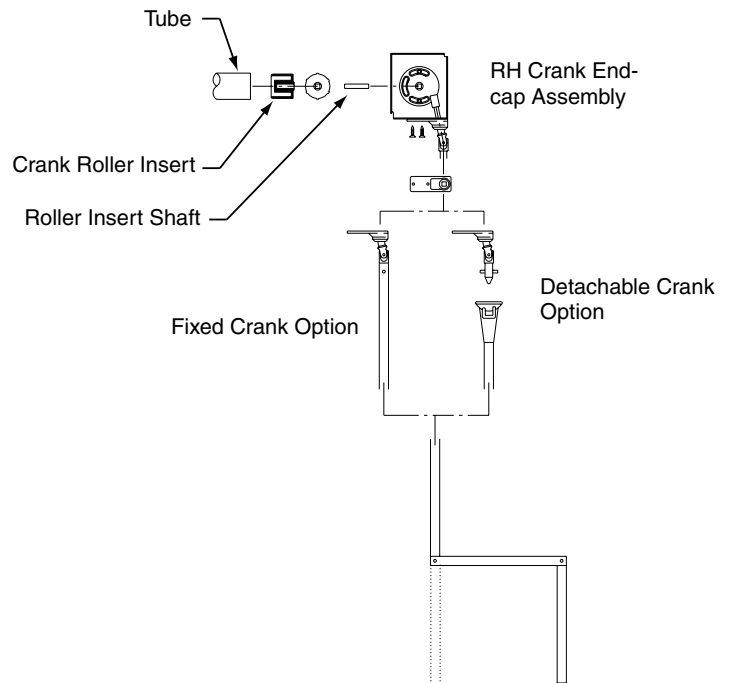
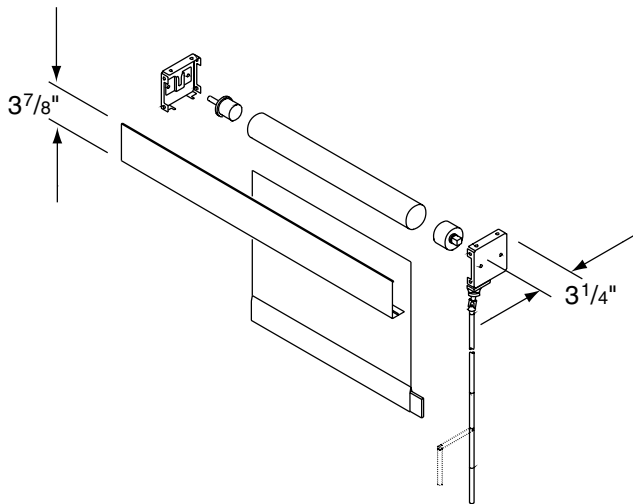

Clutch-operated FlexShade, with standard brackets

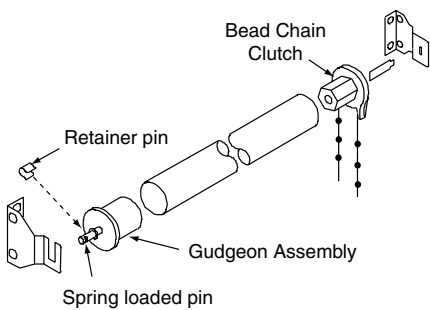

33 1/2" to floor

Manual FlexShade System by Draper

Room Schedule

The following room schedule reflects dimensions verified in the field by _____

| Room/ Loc. | Qty. | Measure | | Dimensions | | <input type="checkbox"/> Spring <input type="checkbox"/> Clutch <input type="checkbox"/> Crank <input type="checkbox"/> Perm <input type="checkbox"/> Detach L R | | Crank Length | Sill Ht. | Fabric Number & Color | Brackets | | Optional Fascia* | Hardware Headbox <input type="checkbox"/> Surface <input type="checkbox"/> Pocket** |
|---------------|------|---------|----|------------|-----------------|--------------------------------------------------------------------------------------------------------------------------------------------------------------------------------------|---------|-----------------|-------------|-----------------------|----------|--|---------------------|----------------------------------------------------------------------------------------------|
| | | IM | OM | Width | Exact Height | Inside/ Outside | Ceiling | | | | | | | |
| | | | | | | | | | | | | | | |
| | | | | | | | | | | | | | | |
| | | | | | | | | | | | | | | |
| | | | | | | | | | | | | | | |
| | | | | | | | | | | | | | | |
| | | | | | | | | | | | | | | |
| | | | | | | | | | | | | | | |
| | | | | | | | | | | | | | | |
| | | | | | | | | | | | | | | |
| | | | | | | | | | | | | | | |
| | | | | | | | | | | | | | | |
| | | | | | | | | | | | | | | |
| | | | | | | | | | | | | | | |
| | | | | | | | | | | | | | | |
| | | | | | | | | | | | | | | |
| | | | | | | | | | | | | | | |
| | | | | | | | | | | | | | | |
| | | | | | | | | | | | | | | |
| | | | | | | | | | | | | | | |

Notes on measuring/ordering Manual FlexShades:

IM—inside measure. Draper makes a 1/8" deduction.

OM—outside measure. No deduction made: width shown is overall unit dimension including brackets or endcaps.

Control location determined by viewing shade from inside the room. Right hand standard.

*If ordering optional fascia or headbox, specify color: (Clear Anodized, standard; Bronze, Ivory, White, and Black Enamel available.)

Orders with fascia or headbox are automatically furnished with endcaps instead of brackets.

There are two types of headboxes: Ceiling/wall (std) or Pocket (optional).

**In addition to the standard pocket headbox, Type D pocket headbox is also available.

1/8" x 1" aluminum slat standardly encased in hem. Over 8' width receives a 13/16" aluminum tube.

Metal bead chain standard. Ivory, Grey or Black plastic chain available on request.